

Connector Cable

■ Type

Appearance		Model	Length	Cable material	
DC 2-wire type connection cable	Socket Type	CID2-2	2m	PVC	
		CID2-2-1 ※			
		CID2-5	5m		
		CID2-5-1 ※			
		Plug Type	CLD2-2		2m
			CLD2-2-1 ※		
	CLD2-5		5m		
	CLD2-5-1 ※				
	DC 3-wire type connection cable	Socket Type	CID3-2		2m
			CID3-5		5m
			CLD3-2		2m
		Plug Type	CLD3-5		5m
CID3-2P			2m		
CLD3-2P			2m		
DC 4-wire type connection cable	Socket Type	CIDH4-2	2m		
		CIDH4-5	5m		
		CLDH4-2	2m		
	Plug Type	CLDH4-5	5m		
		CIDH4-2P	2m		
		CIDH4-5P	5m		
AC 2-wire type connection cable	Socket Type	CLDH4-2P	2m		
		CLDH4-5P	5m		
		CIA2-2	2m		
	Plug Type	CIA2-5	5m		
		CLA2-2	2m		
		CLA2-5	5m		
AC 2-wire type connection cable	Socket Type	CIA2-2P	2m		
		CIA2-5P	5m		
		CLA2-2P	2m		
	Plug Type	CLA2-5P	5m		

▶ "※" mark indicates IEC standard connection and it can be customized.

▶ Be careful of connection, because color is different when DC 4-wire connector cable is used for DC 2-wire sensor.

■ Type

Appearance		Model	Length	Cable material	
Socket - Plug Type	DC type	C1D4-2	2m	PVC	
		C1D4-5	5m		
		AC type	C1A4-2		2m
			C1A4-5		5m
		DC type	C2D4-2		2m
			C2D4-5		5m
	AC type	C2A4-2	2m		
		C2A4-5	5m		
	DC type	C3D4-2	2m		
		C3D4-5	5m		
		AC type	C3A4-2		2m
			C3A4-5		5m
DC type		C4D4-2	2m		
		C4D4-5	5m		
AC type	C4A4-2	2m			
	C4A4-5	5m			
Plug - Plug Type	DC type	C1D4-2P	2m		
		C1D4-5P	5m		
	AC type	C1A4-2P	2m		
		C1A4-5P	5m		

(A) Counter

(B) Timer

(C) Temp. controller

(D) Power controller

(E) Panel meter

(F) Tacho/Speed/Pulse meter

(G) Display unit

(H) Sensor controller

(I) Switching power supply

(J) Proximity sensor

(K) Photo electric sensor

(L) Pressure sensor

(M) Rotary encoder

(N) Stepping motor & Driver & Controller

(O) Graphic panel

(P) Production stoppage models & replacement

Connector Cable

■ Dimensions

◎ Connector cable(Socket type)

(Unit:mm)

- CID2-□, CID2-□-I ● CID3-□ ● CIA2-□

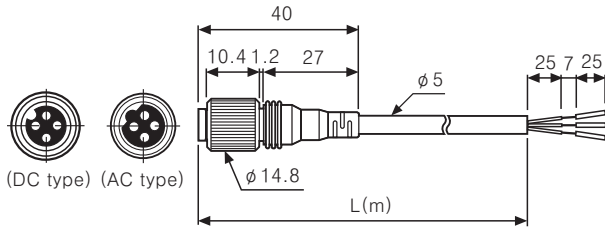

- CLD2-□, CLD2-□-I ● CLD3-□ ● CLA2-□

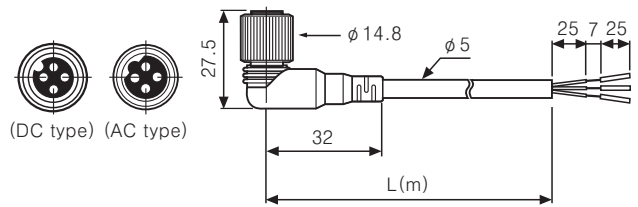

◎ Connector cable(Plug type)

(Unit:mm)

- CID2-2P ● CIA2-2P ● CID3-2P

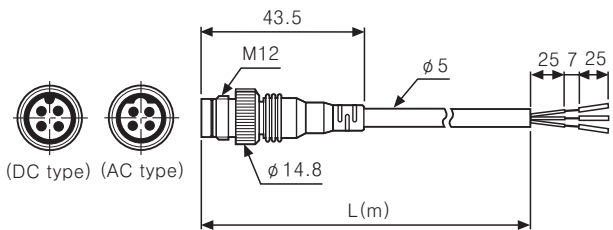

- CLD2-2P ● CLA2-2P ● CLD3-2P

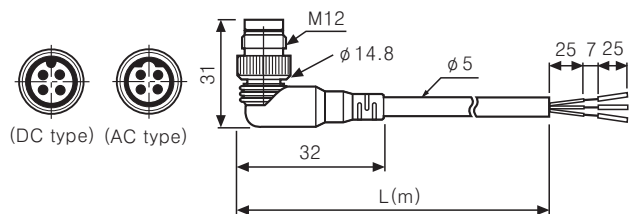

◎ Connector cable(Socket-Plug type)

(Unit:mm)

- C1□4-□ (Standard type)

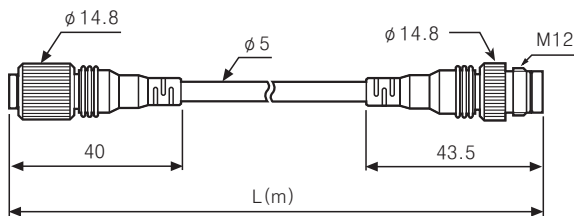

- C3□4-□ (Straight type = L type)

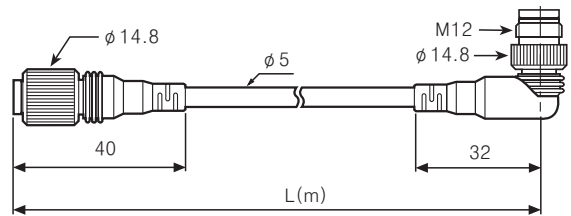

- C2□4-□ (L type = L type)

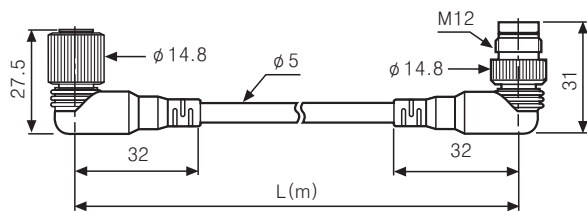

- C4□4-□ (L type = Straight type)

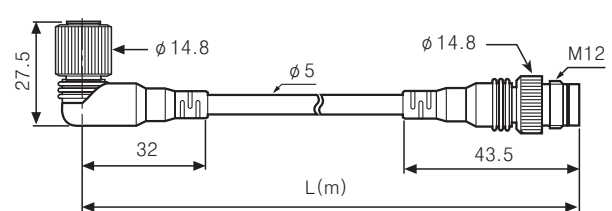

◎ Connector cable(Plug - Plug type)

- C1D4-□P, C1A4-□P

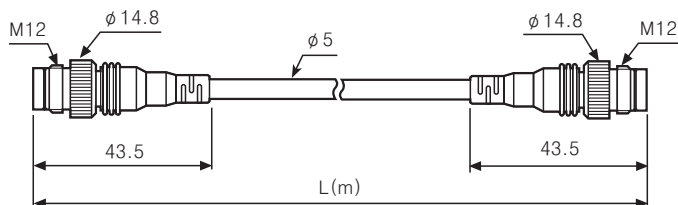

(Unit:mm)

Connector Cable

Connections

◎Connector cable

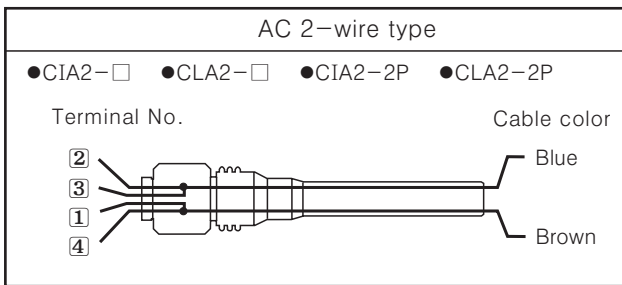
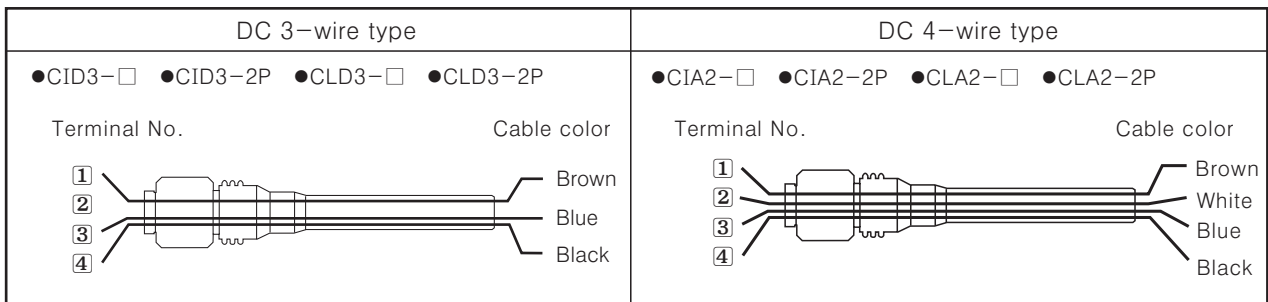
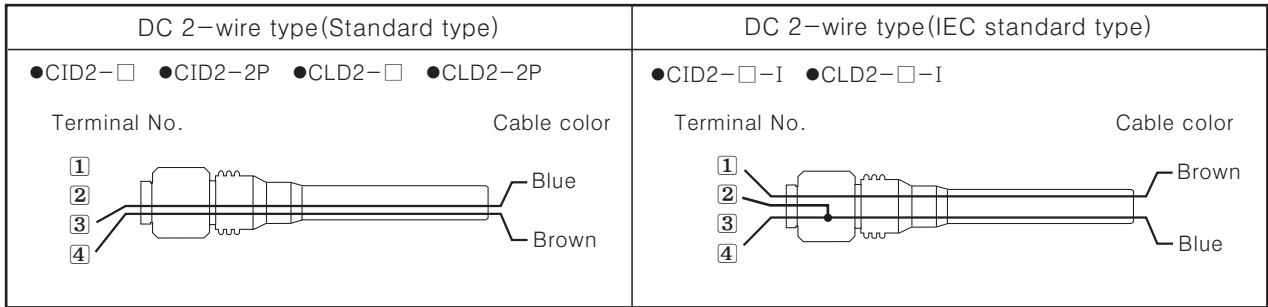

◎Connector cable

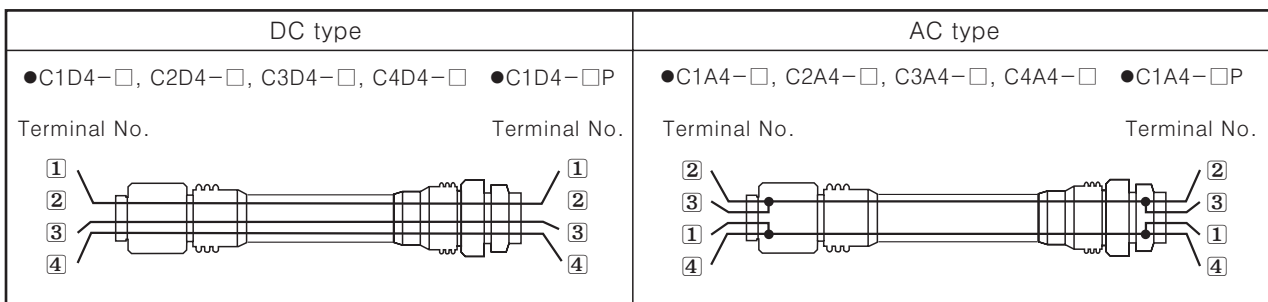

※Pin ② is N.C.(Not Connected).

※Pin ② / ③, ① / ④ are connected inside.

Connections

●Socket type connection

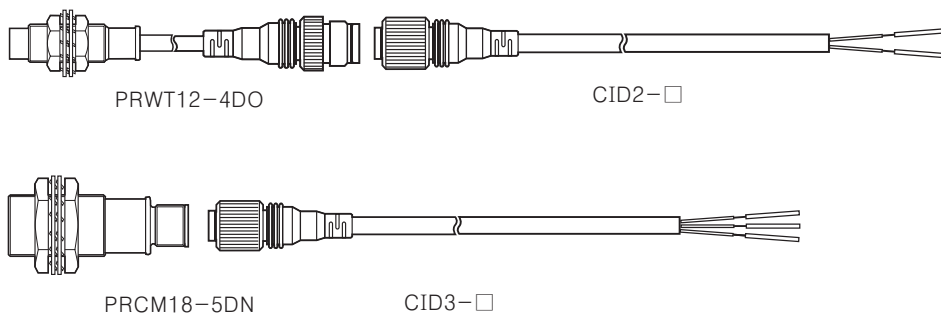

(A)
Counter

(B)
Timer

(C)
Temp.
controller

(D)
Power
controller

(E)
Panel
meter

(F)
Tacho/
Speed/
Pulse
meter

(G)
Display
unit

(H)
Sensor
controller

(I)
Switching
power
supply

(J)
Proximity
sensor

(K)
Photo
electric
sensor

(L)
Pressure
sensor

(M)
Rotary
encoder

(N)
Stepping
motor &
Driver &
Controller

(O)
Graphic
panel

(P)
Production
stoppage
models &
replacement

Connector Cable

● Plug Type

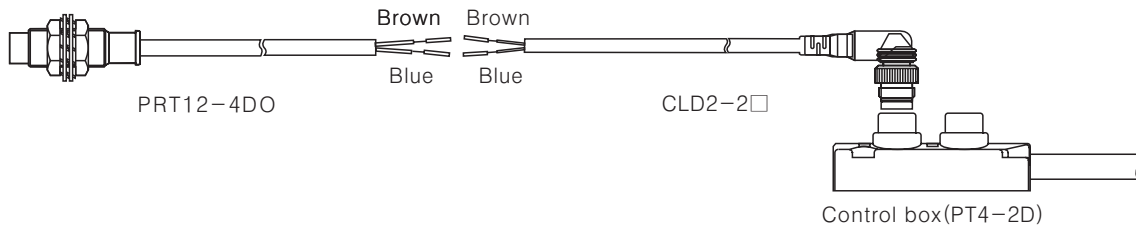

● Connector cable(Socket-plug type)

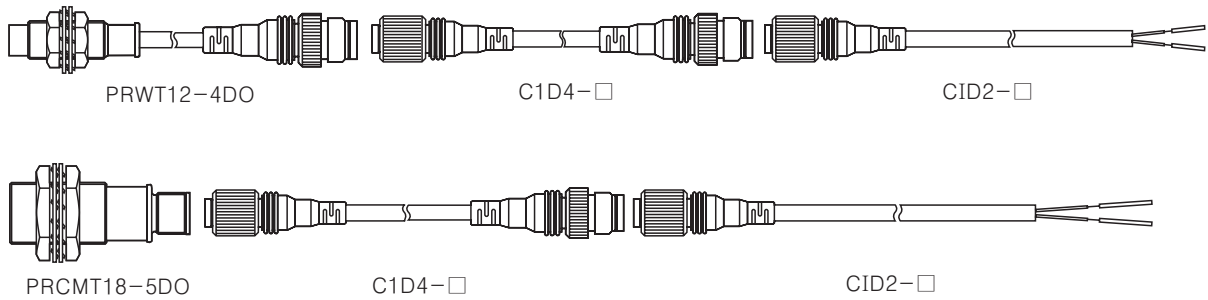

■ Connector for panel mounting

◎ Connector for panel mounting(Non-flush)

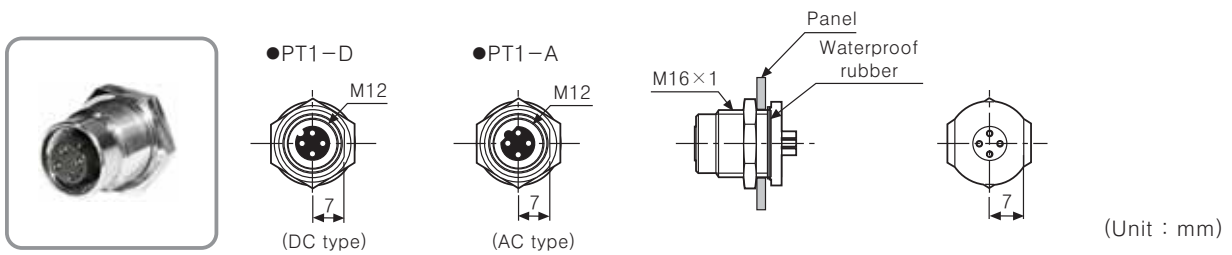

◎ Connector for panel mounting(Flush)

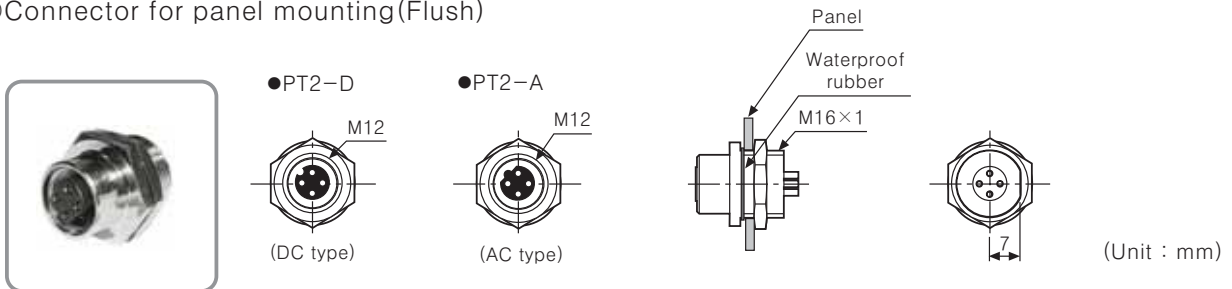

◎ Panel cut-out

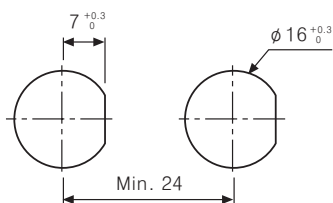

◎ PCB size

